

HP Twin Lift FW-Flip

Item no.: 8269

lift system for floor-wall mounting, display specific for Samsung Flip

The HP Twin Lift FW-Flip is a height adjustable lift system for floor-wall mounting. Designed display specific for Samsung WM55H, WM55R and WM55B.

The Samsung Flip can be rotated von landscape to portrait format and vice versa, if desired. Thanks to the included spring mechanism the format change is possible with little effort. The screen locks in the desired end position and can be - without unlocking - released from the end position.

The system is motorized and the height can be adjusted by a wired remote control. The start and end point can be programmed and thus adjusted to the individual needs.

The lift system also has collision prevention, which stops the screen from moving as soon as resistance occurs.

Thanks to the floor-wall mounting the lift system doesn't need much space. The floor space required is W 825 x D 275 mm.

The HP Twin Lift FW-Flip has an integrated media cabinet, which is lockable and thus securely protects the AV equipment stored there from unauthorised access.

Cable management is neatly organized via a cable drag chain.

The max. load is 45 kg.



Cable management by cable drag chain



Release from the end position without unlocking

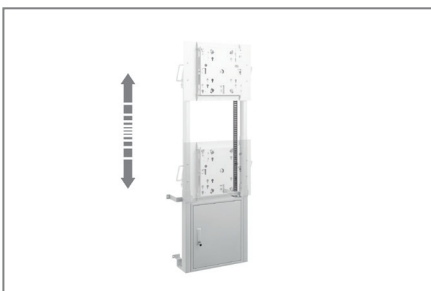

motorized height adjustment

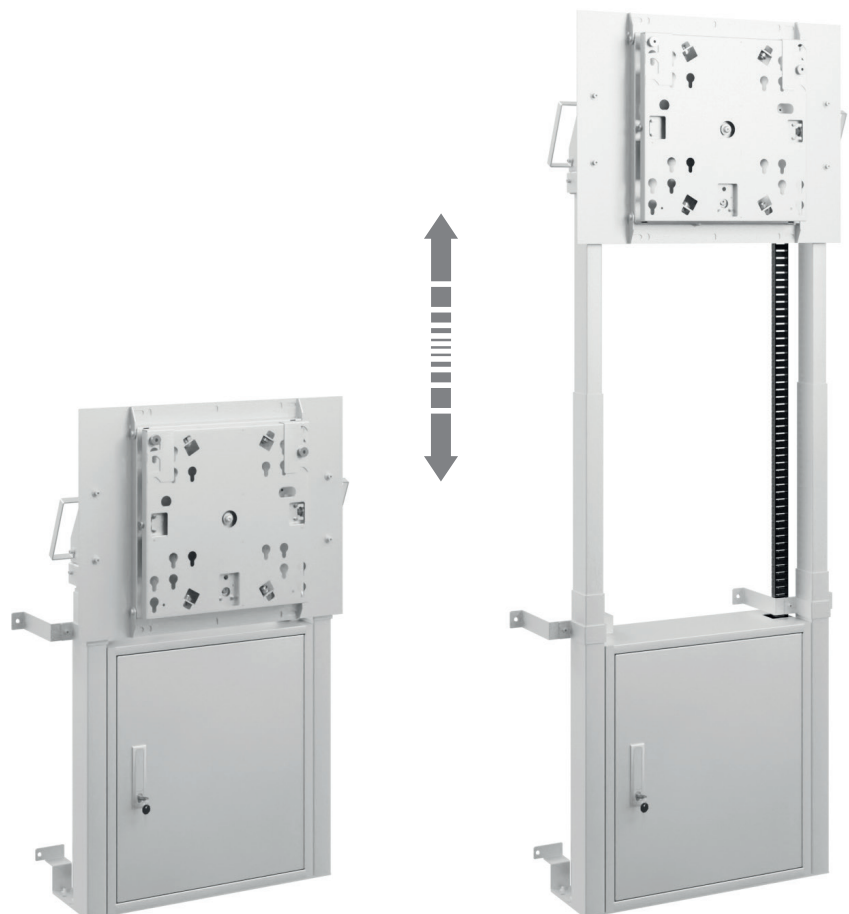

HP Twin Lift FW-Flip

Item no.: 8269

lift system for floor-wall mounting, display specific for Samsung Flip

- display specific for Samsung WM55H | WM55R | WM55B
- VESA 200 x 200 mm / 300 x 300 mm / 400 x 400 mm
- electromotive height adjustment
- operation via wired touch control
- collision prevention - lift stops if there is resistance
- freely rotatable by -90°
- rotatable from landscape to portrait format and vice versa
- cable management via cable drag chain
- little effort thanks to spring mechanism
- locks in the respective end position
- release from the end position without unlocking
- tilting possible with tools ($0^\circ / \pm 2.5^\circ / \pm 5^\circ$)
- lockable media cabinet
- space saving floor-wall mounting
- 45 kg max. load
- colour: white
- optional:
Flip adapter 65" WM65R | WM65B (Item no.: 5761)

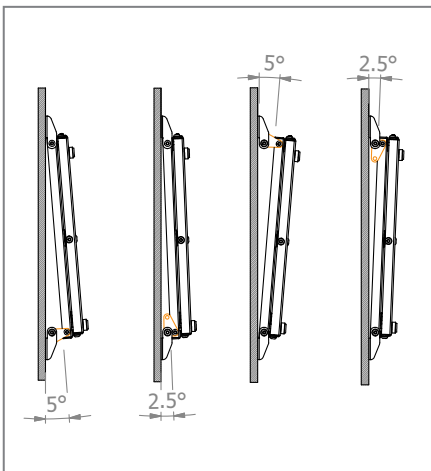

Tilting possible ($0^\circ / \pm 2.5^\circ / \pm 5^\circ$)

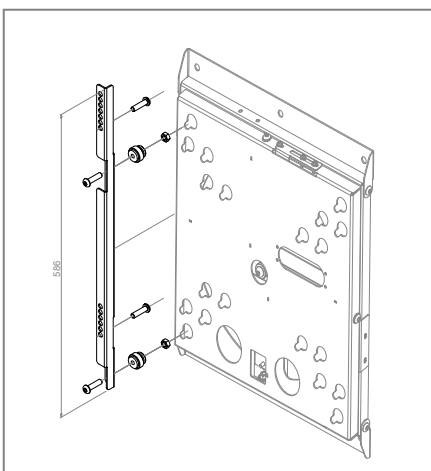

Flip adapter 65" WM65R / WM65B
(Item no.: 5761)

